

Wood-shop

THE CREEPIE STOOL

The pages which follow will guide you through the making of The Creepie Stool, step by step using hand tools. This project is the first part of a cabinet-making course and a set of guidance notes called 'The Background' is available which give an introduction and preparation to the course. For best results please follow the drawings at the end of this manual as well as the step-by-step instructions. You will need a basic tool kit. In this manual there is an optional section if you have a multiplane.

Included with the kit you will find -

Screws - 10 off 35 x 4; 6 off 30 x 4

Dowels - 8 off 8mm x 40mm

You will also need glue and some scraps of wood for templates, packers etc but these are not included.

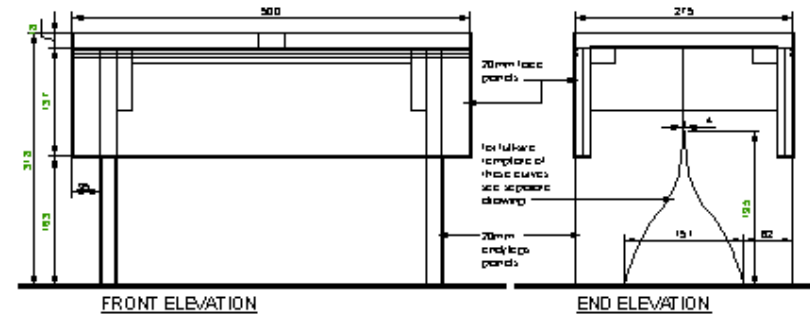

The Wood-Shop
Lethenty Mill Furniture
Inverurie
Aberdeenshire
AB51 0HQ
Tel. 01467 622489
Fax. 01467 629631
Website:
www.wood-shop.co.uk
Email:
info@wood-shop.co.uk



Part No.	No. of Pieces	ITEM name	Thickness mm	Width mm	Length mm	Wood Type	Wood Character
1	2	Top	20	145	500		
2	2	Side	20	145	500		
3	4	End/leg	20	140	318		
4	2	Fixing rail	20	70	231		
5	2	Fixing block	20	30	80		

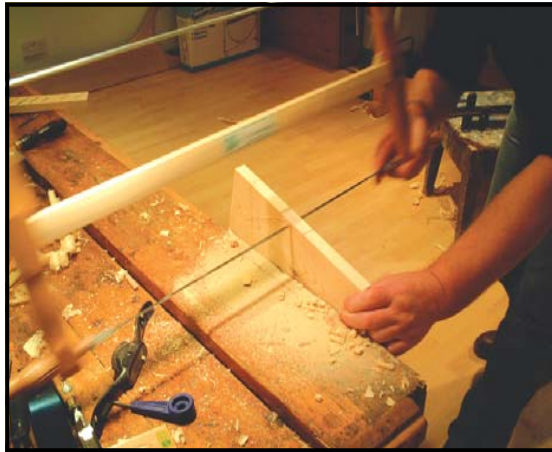

(i)



(k)

Background

From Scottish Literature –

A seat in a church where unmarried parents sat,
When they sat there it meant that they were bound to provide and care for the child. Robert Burns and his paramour Jean Armour had to perform this ritual for no less than 3 consecutive Sundays in Mauchline Church.

Creepie, often used with stule, chair ... low legged stool placed by fire often for children - also as 'creepi' in church for elevating preacher in pulpit. Carried to church by the parishioners, or for weddings, in the days when pews were only provided for the toffs!

A favourite Scottish tale from the 17th Century describes how a kail-wife, Jenny Geddes, demonstrated her wrath at the attempted introduction of The English Book of Prayer (during a service at St.Giles Cathedral) by hurling her stool at the Dean of the Kirk, yelling ... "Deil colic the wame o' ye!" (May the Devil buckle your belly). This much applauded sentiment was to lead to the signing of "The National Covenant" in Greyfriars Churchyard in 1638, the abolition of the Episcopal faith in Scotland (at that time) and Scotland's part in the Civil Wars of these islands.

HEALTH CHECK

NEVER put your other hand in front of a Hand Tool; Chisel; Bradawl or Saw!



(l)



(m)

General Layout : Scale 1:5

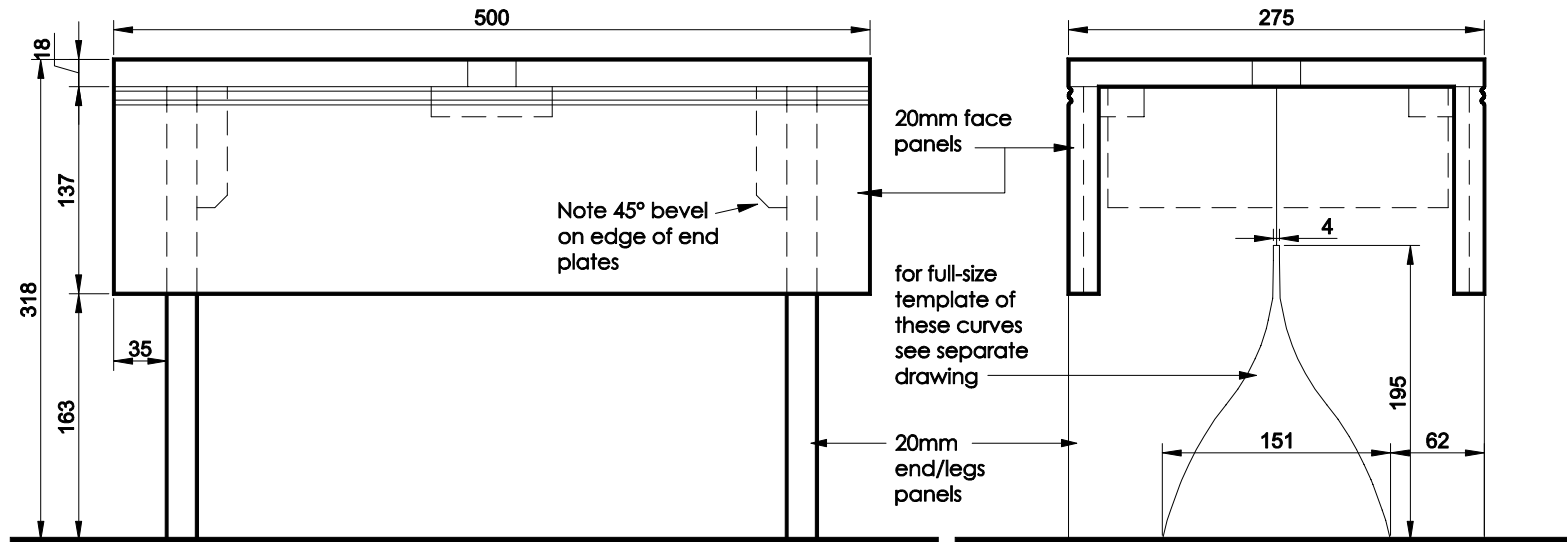

FRONT ELEVATION

END ELEVATION

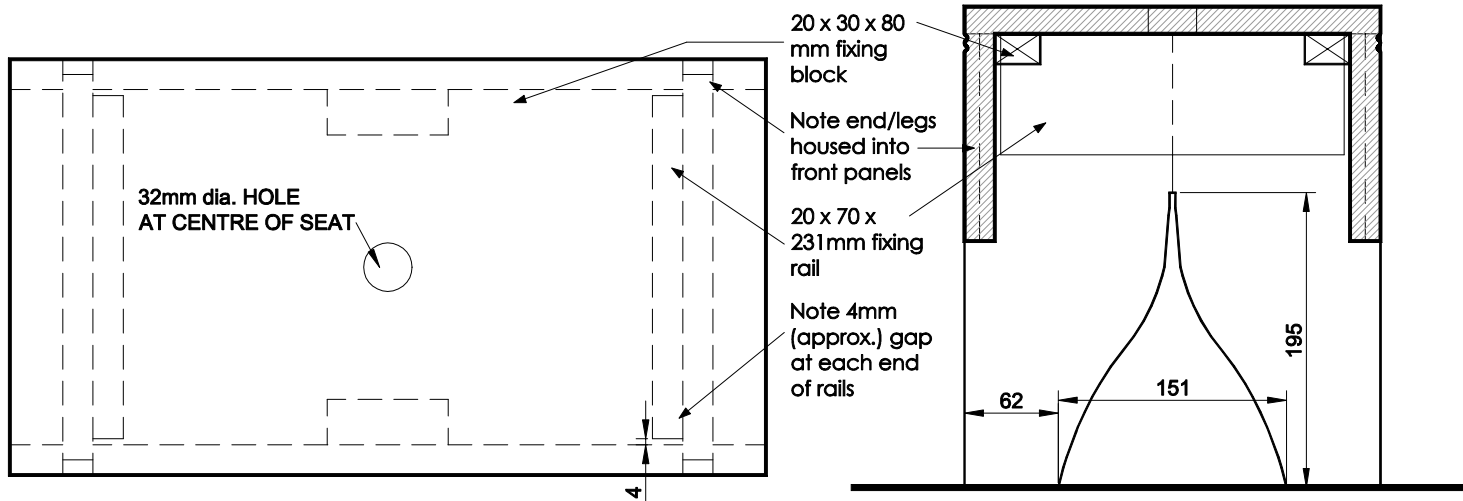

PLAN VIEW

CROSS SECTION